

HIAB T-HIDUO 029



HIAB T-HIDUO 029 BASIC DATA

Technical data	HIDUO CE/CEN 029-2	HIDUO CE/CEN 029-3	HIDUO CE/CEN 029-4
Max. lifting capacity (kNm)	27,2	27,1	26,1
Lifting capacity (tm)	2,8	2,8	2,7
Outreach / lifting capacity, hydraulic extension (m/kg)	1.5/1860 2.4/1140 3.4/800	1.5/1840 2.4/1120 3.4/780 4.4/600	1.6/1660 2.5/1020 3.5/720 4.5/540 5.5/440
Outreach / lifting capacity, manual extension (m/kg)	4.4/600 5.5/450	5.5/440	
Outreach, hydraulic extensions (m)	1,9	2,9	3,9
Hydraulic boom extensions (m)	3,4	4,4	5,5
Outreach, manual extensions (m)	2,1	1,1	
Lifting height above installation level (m)	4,7	5,7	6,7
Manual lifting height above installation level inc. Manual ext.(m)	6,7	6,7	
Recommended oil flow (l/min)	10	10	10
Power needed at rec. oil flow (kW)	3	3	3
Max. working pressure (MPa)	17,5	17,5	17,5
Tank Capacity PTO (l)	18	18	18
Slewing angle (°)	322	322	322
Max. slope viable at full capacity (°)	5	5	5
Slewing torque, gross (kNm)	3	3	3
Slewing speed (°/s)	10	10	10
Height in folded position (mm)	1551	1551	1551
Width in folded position staticmounted (mm)	798	798	798
Width in folded position truck mounted (mm) no stab beam/with stab beam and tilting	1826/1926	1826/1926	1826/1926
Installation space needed static mounted (mm)	300	300	300
Installation space needed truck mounted (mm)	536	536	536
Weight, static mounted (kg)	275	313	351
Weight, mounting frame plus 2 short hydr. stabilizer legs (kg)	121	121	121

This table shows a few examples of models, and represents some of all options available. With the opportunity to configure your crane, we can provide you with a crane perfectly tailored to your needs.

Please contact your local dealer for more information on the variety of options we can offer.

HIAB T-HIDUO 029-2

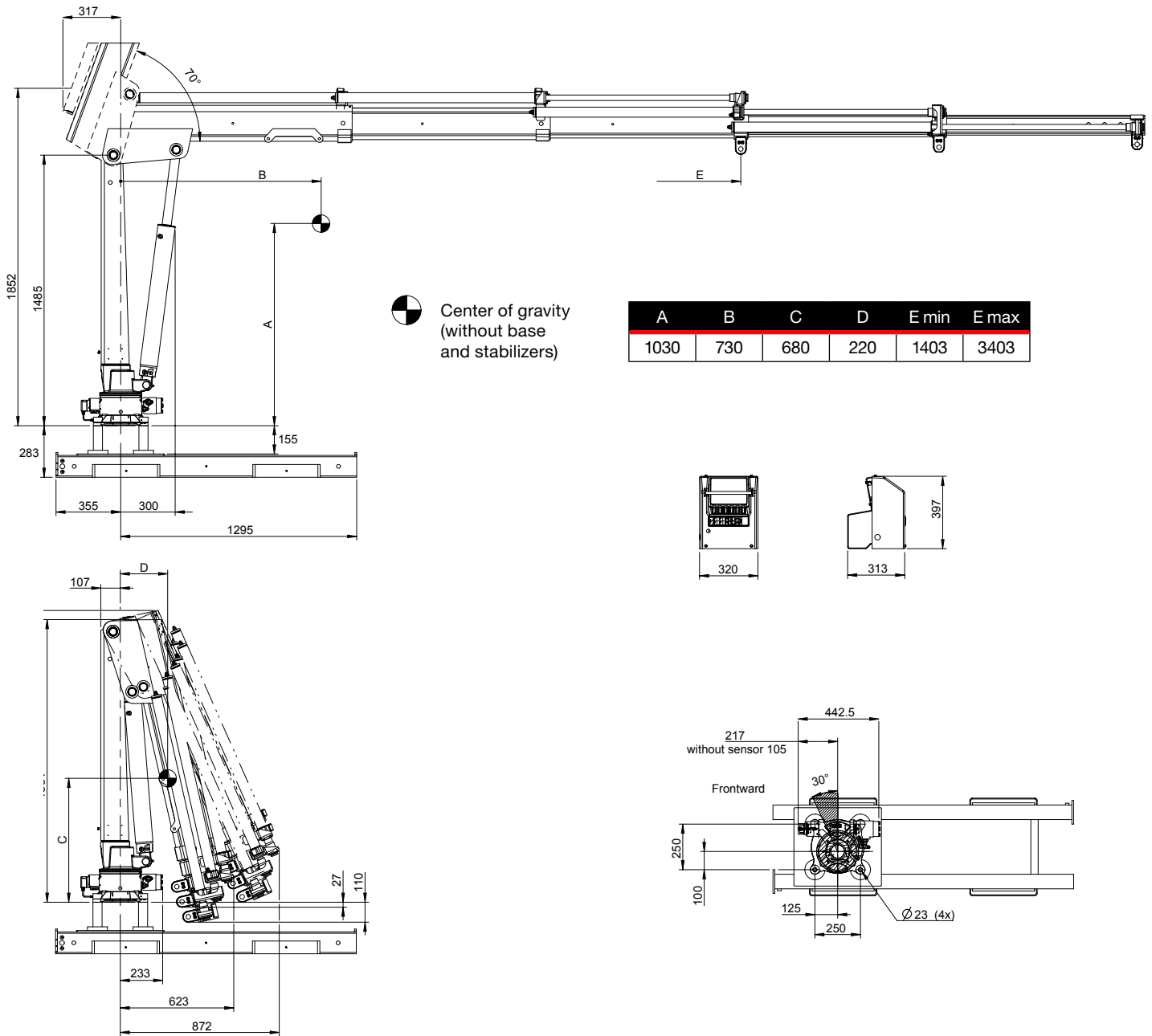

Capacity plate HIAB T-HIDUO 029-2

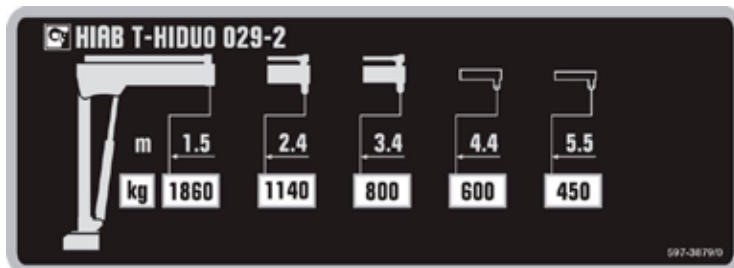

Load diagram HIAB T-HIDUO 029-2

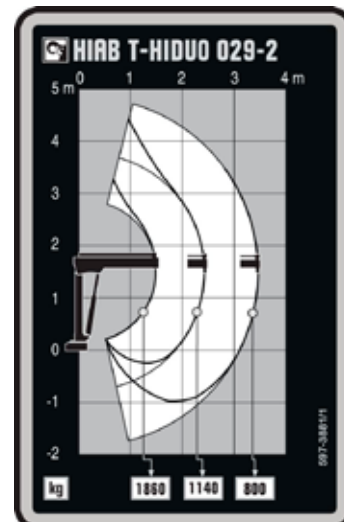

HIAB T-HIDUO 029-3

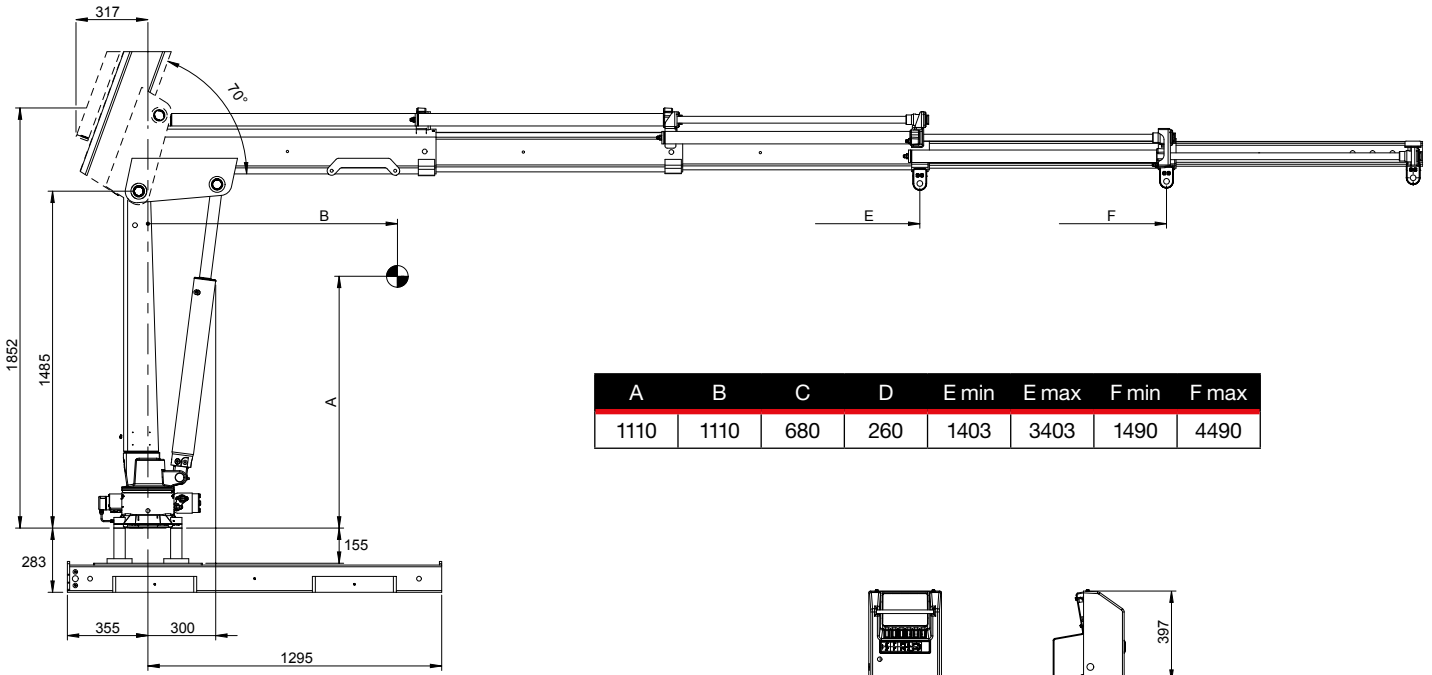

A	B	C	D	E min	E max	F min	F max
1110	1110	680	260	1403	3403	1490	4490

 Center of gravity (without base and stabilizers)

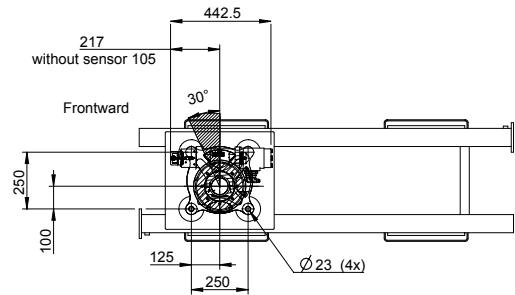
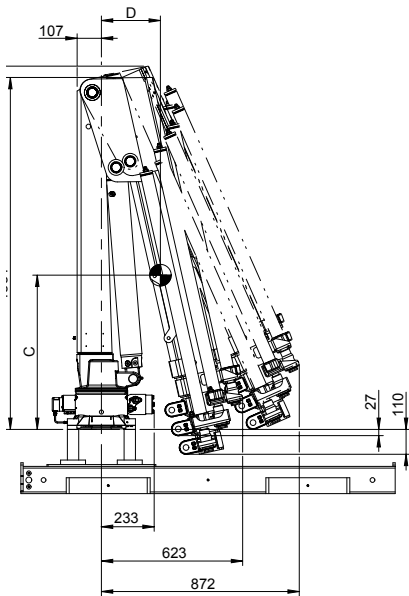
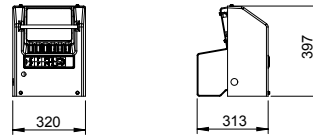

Capacity plate HIAB T-HIDUO 029-3

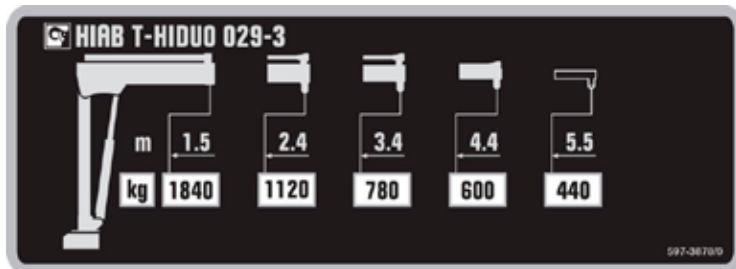

Load diagram HIAB T-HIDUO 029-3

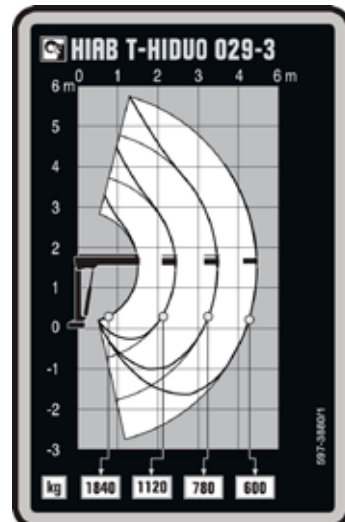

HIAB T-HIDUO 029-4

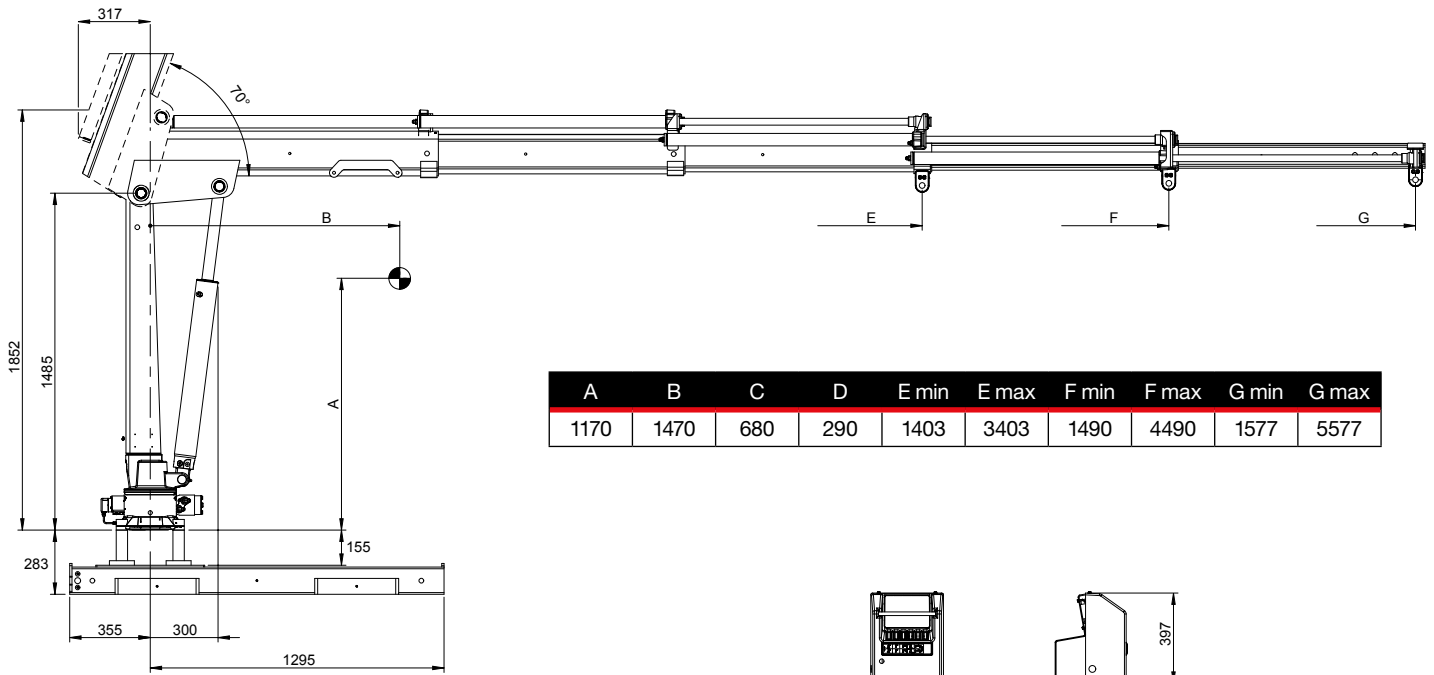

A	B	C	D	E min	E max	F min	F max	G min	G max
1170	1470	680	290	1403	3403	1490	4490	1577	5577

 Center of gravity (without base and stabilizers)

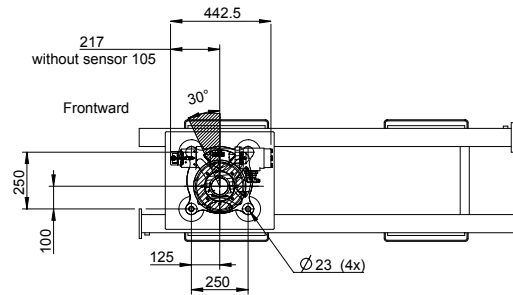
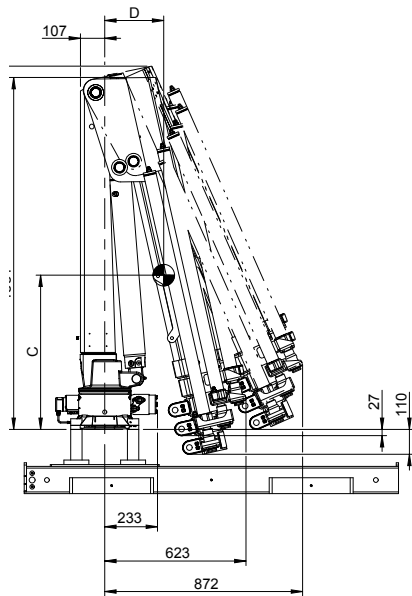
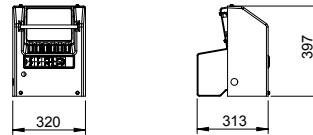

Capacity plate HIAB T-HIDUO 029-4

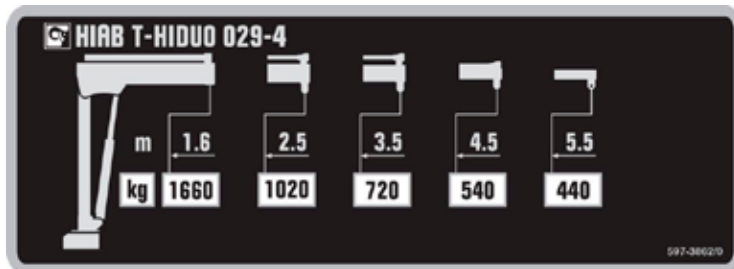

Load diagram HIAB T-HIDUO 029-4

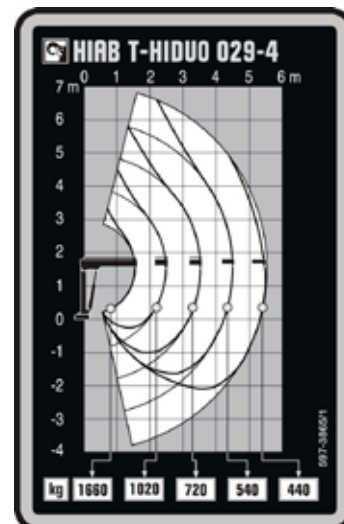

HIAB T-HIDUO 029

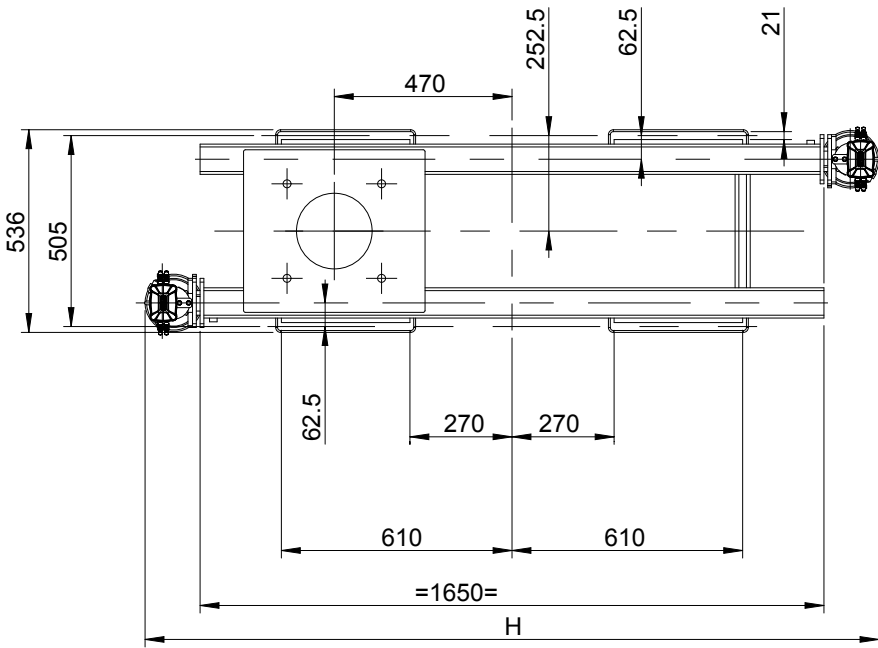

Base	H
Fixed	1826
Fixed with tilting device	1886
Extension	1866
Extension with tilting device	1926

Tiltable stabilizer leg parking positions

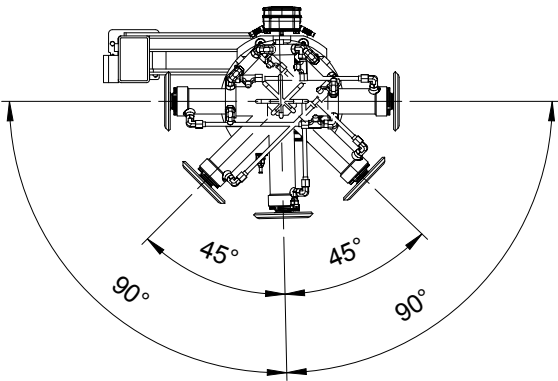

HIAB T-HIDUO 029

Hydraulic stabilizer leg

Hydraulic stabilizer leg

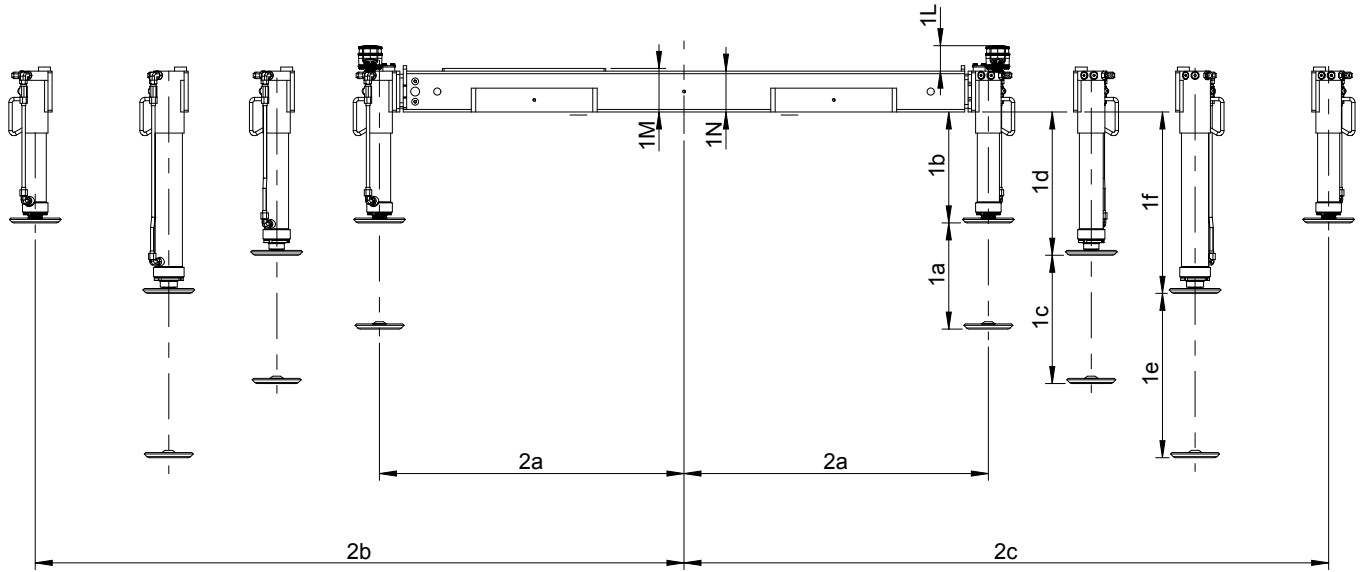

Other base dimensions

	Fixed stabilizer leg position	Tiltable stabilizer leg
1L	75	52
1M	128	128
1N	120	120

Stabilizer leg length

		Tiltable stabilizer leg		Fixed stabilizer leg position
Manual stabilizer leg	Short	1a	216	216
		1b	330.5	353.5
	Medium	1c	418	418
		1d	498.5	521.5
Hydraulic stabilizer leg	Short	1e	312	312
		1f	326	349
	Medium	1g	377	377
		1h	421	444
	Long	1i	483	483
		1j	533	556

Base width

		Fixed stabilizer leg	Outrigger beam length Short (300 mm)	Outrigger beam length Medium (600 mm)	Outrigger beam length Long (1100 mm)
Hydraulic stabilizer leg	2a	875	895	895	895
	2b		1195	1695	1995
	2c		1195	1695	1995
Tiltable stabilizer leg	2a	905	925	925	925
	2b		1225	1725	2025
	2c		1225	1725	2025

BUILT TO PERFORM

Hiab is the world's leading provider of on-road load handling equipment. Customer satisfaction is the first priority for us. Hiab's product range includes HIAB loader cranes, JONSERED recycling and forestry cranes, LOGLIFT forestry cranes, MOFFETT truck mounted forklifts and MULTILIFT demountables, as well as DEL, WALTCO and ZEPRO tail lifts.

hiab.com

Hiab is part of Cargotec.

cargotec.com

Disclaimer. We reserve the right to make changes. Illustrations, drawings and data are not always in accordance with the latest version or standard model in production. The models in the pictures may present special equipment or colours.

TD-THIDUC028-EN-EU_160701