

Hiab Jonsered 1200

Capacity 12 tm



Hiab Jonsered 1200 Basic data

Technical data	79	84	96 DT	101 DT
Max. Lifting capacity, net (kNm)	114	111	107	107
Max. Outreach (m)	7.9	8.4	9.6	10.1
Hydraulic boom extension (m)	1.6	1.6	3.2	3.2
Outreach / Lifting capacity, standard (m / kg)	3.0 / 3640 4.0 / 2770 5.0 / 2280 6.0 / 1930 7.0 / 1650 7.9 / 1450 - -	3.0 / 3630 4.0 / 2730 5.0 / 2220 6.0 / 1880 7.0 / 1610 8.4 / 1300 - -	3.0 / 3410 4.0 / 2600 5.0 / 2140 6.0 / 1820 7.0 / 1540 8.0 / 1340 9.0 / 1180 9.6 / 1080	3.0 / 3400 4.0 / 2590 5.0 / 2130 6.0 / 1810 7.0 / 1530 8.0 / 1330 9.0 / 1170 10.1 / 990
Recommended oil flow – variable displacement pump (l/min)	160	160	160	160
Max. working pressure (MPa)	24	24	24	24
Slewing system	double	double	double	double
Slewing angle	425°	425°	425°	425°
Slewing torque, gross (kNm)	27.5	27.5	27.5	27.5
Weight, crane with cabin (kg)	2600	2640	2750	2790

Cabin (standard size), stabilizers A

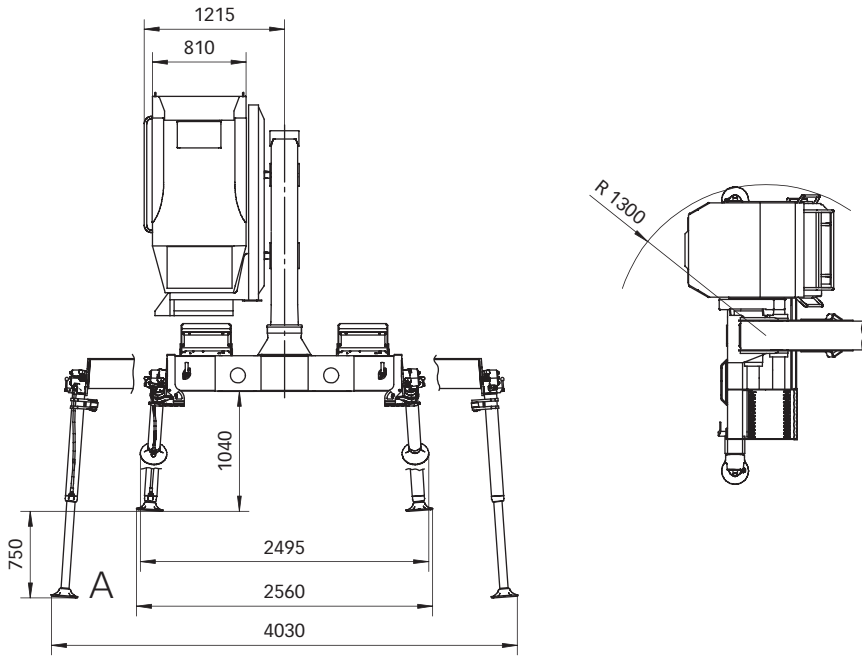

Stabilizers H, F

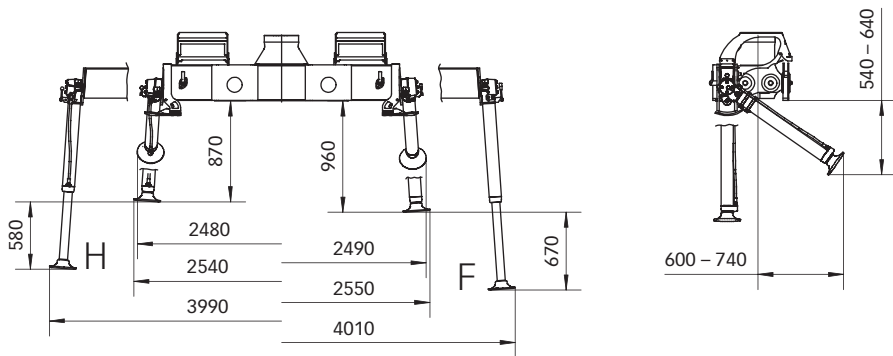

Standard fastening

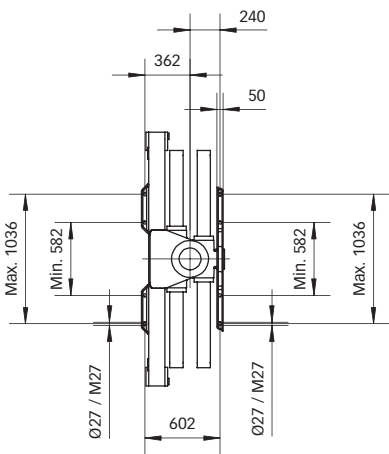

Broad fastening

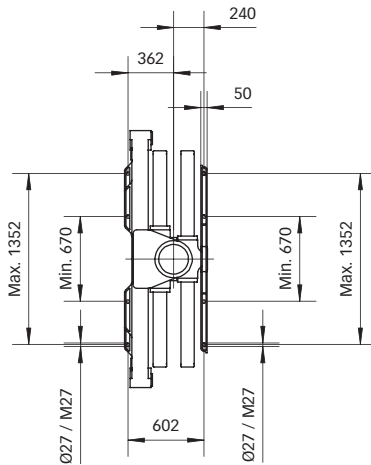

Hiab Jonsered 1200-79

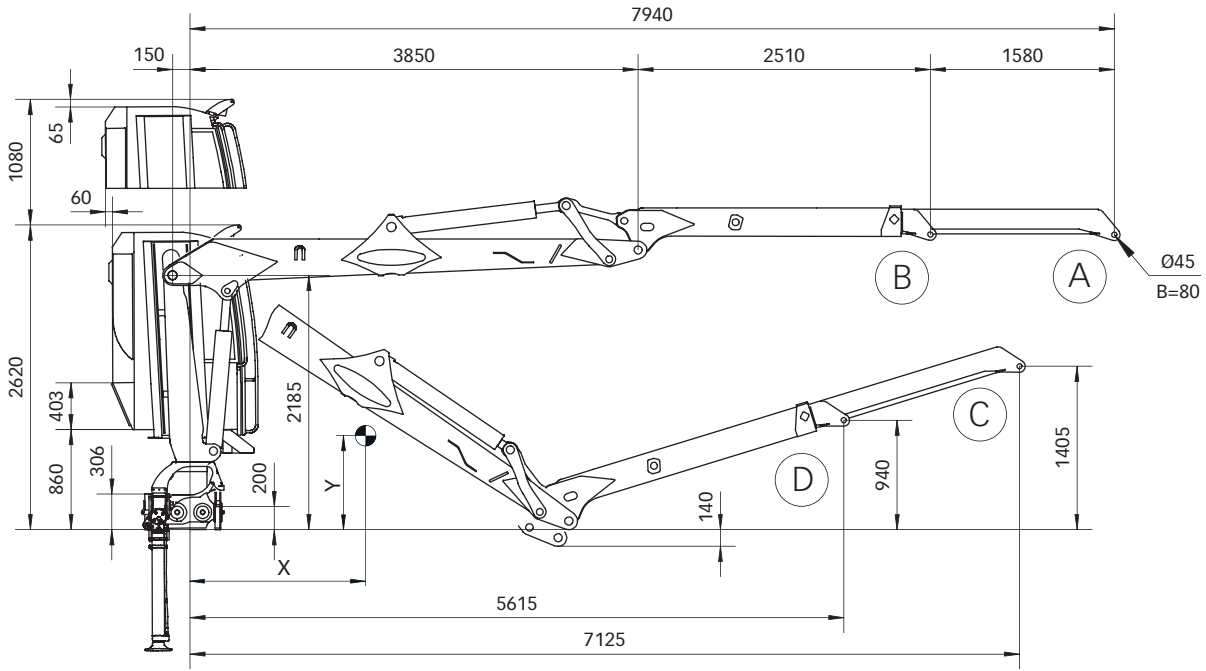

Centre of gravity at	X (mm)	Y (mm)
A	900	1130
B	850	1130
C	770	710
D	720	700

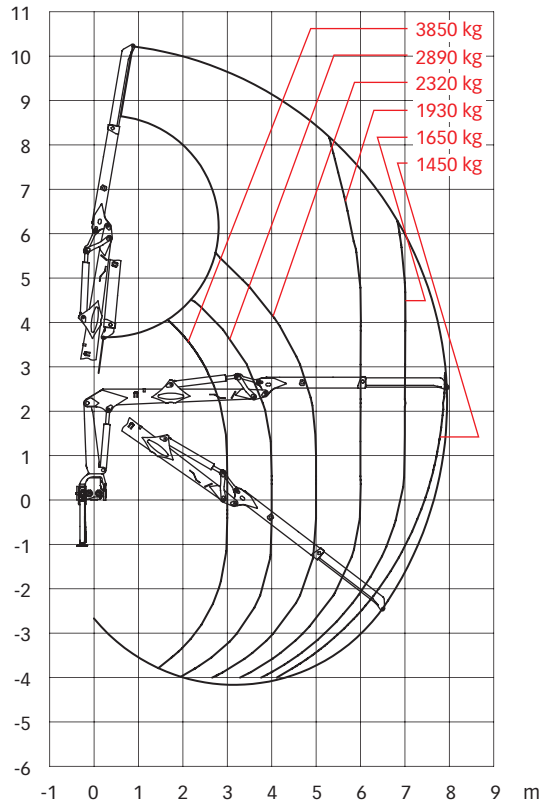

Hiab Jonsered 1200-84

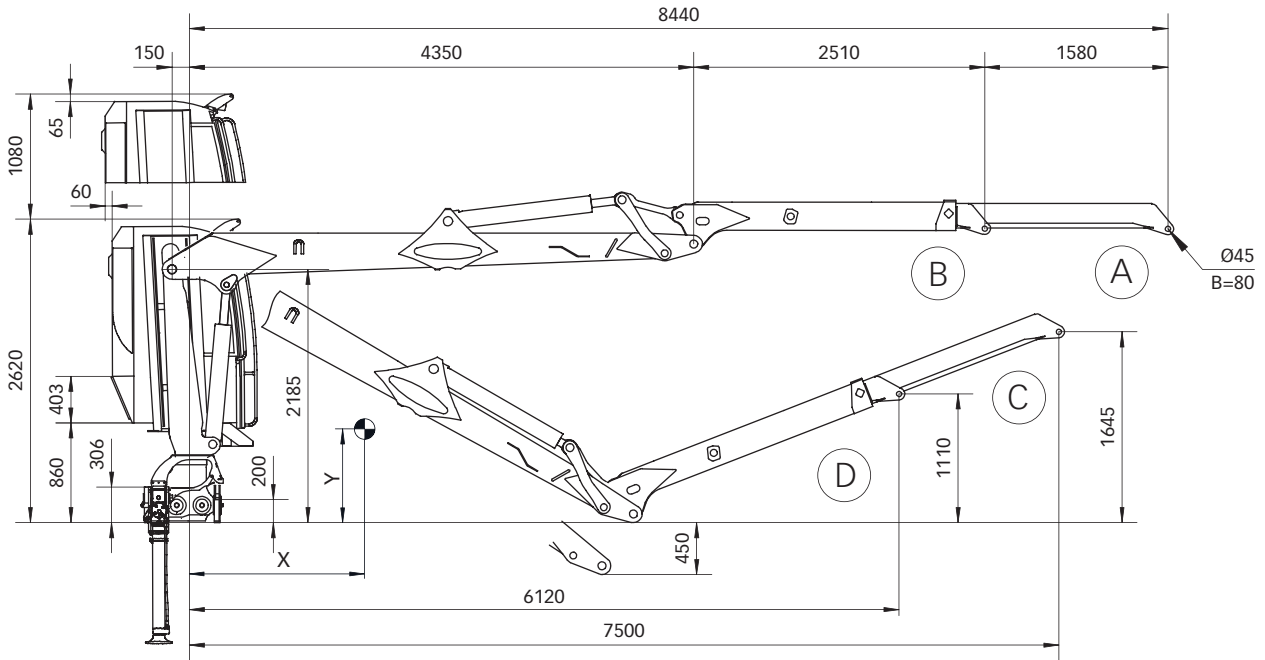

Centre of gravity at	X (mm)	Y (mm)
A	1010	1150
B	960	1150
C	870	720
D	820	710

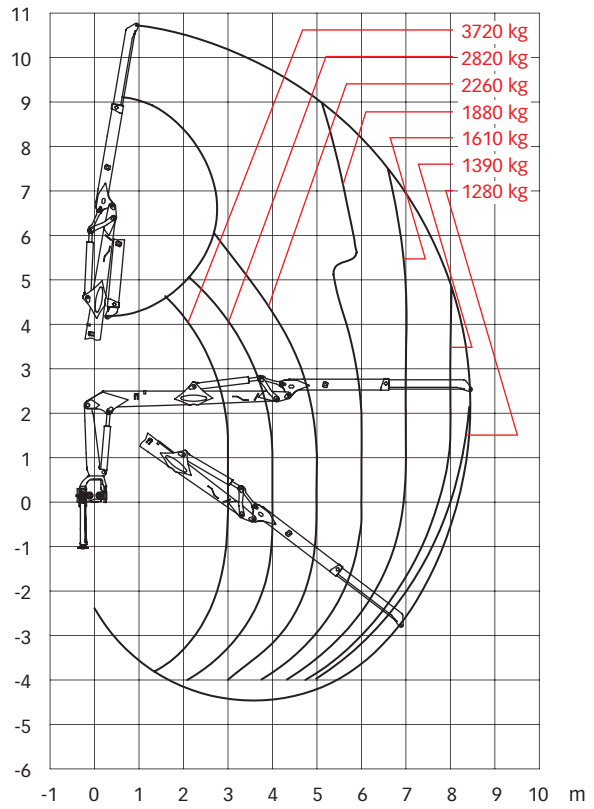

Hiab Jonsered 1200-96 DT

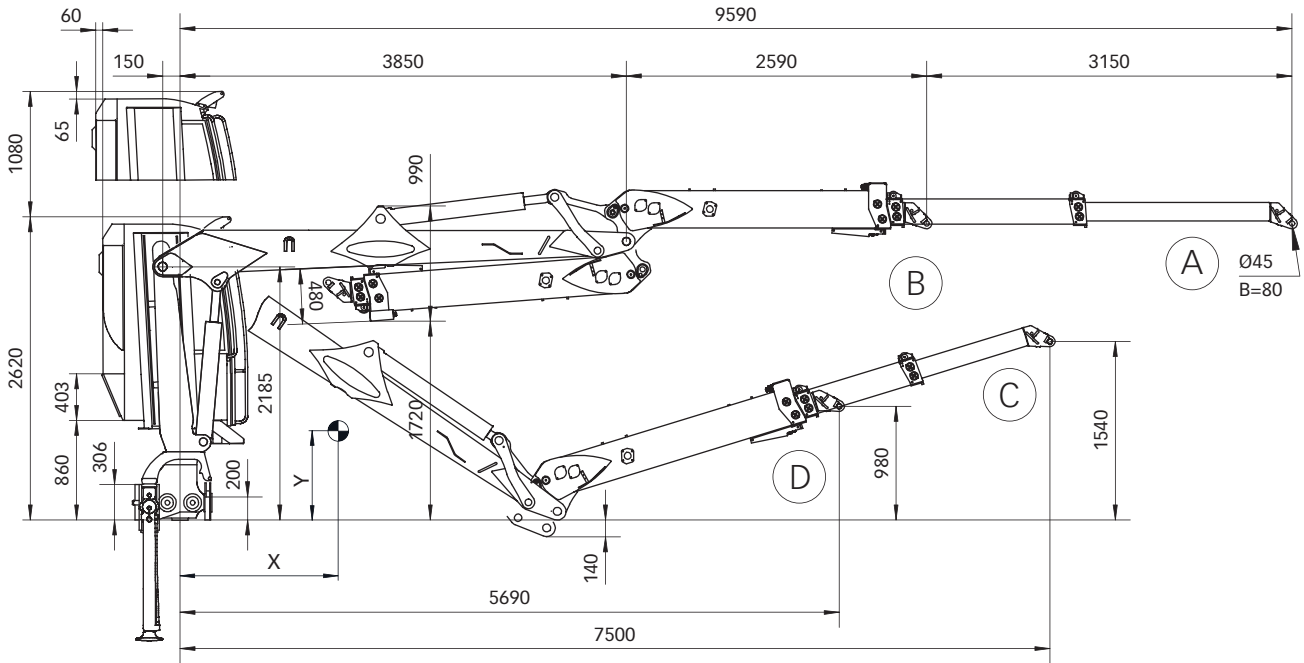

Centre of gravity at	X (mm)	Y (mm)
A	1210	1210
B	1070	1210
C	990	720
D	910	710

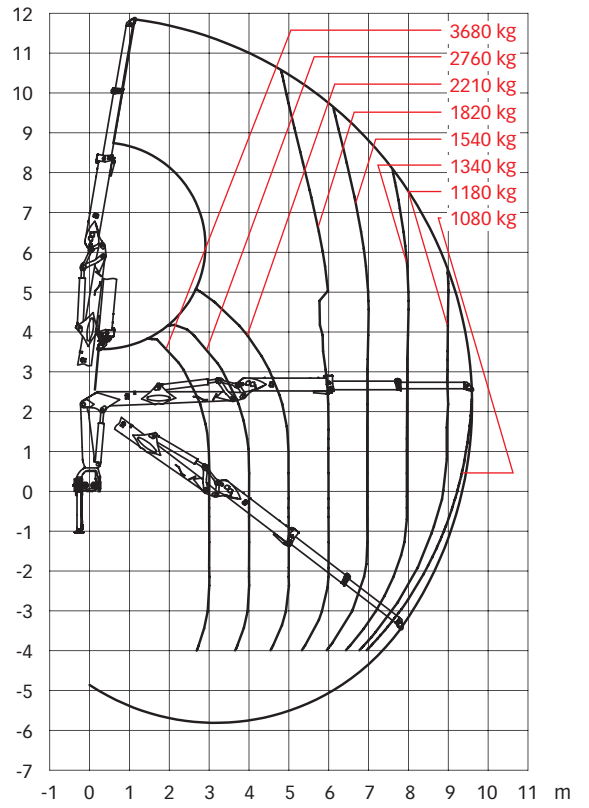

Hiab Jonsered 1200-101 DT

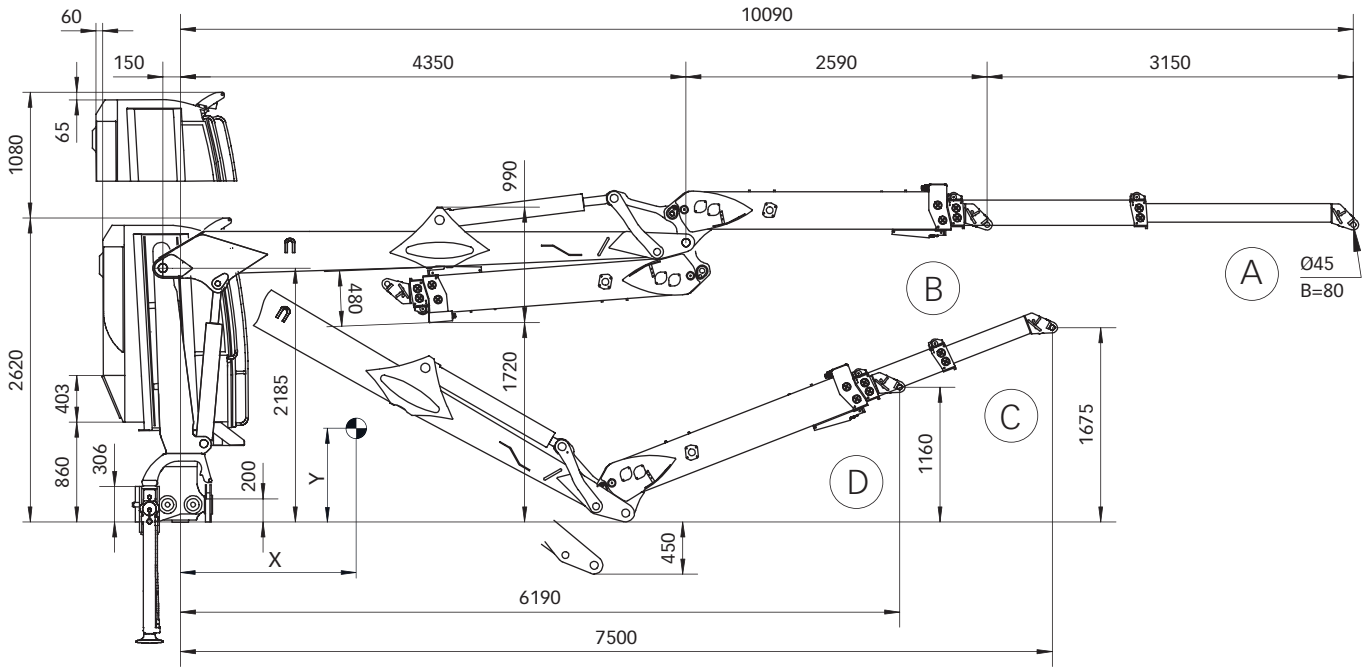

Centre of gravity at	X (mm)	Y (mm)
A	1310	1230
B	1170	1230
C	1080	740
D	1000	720

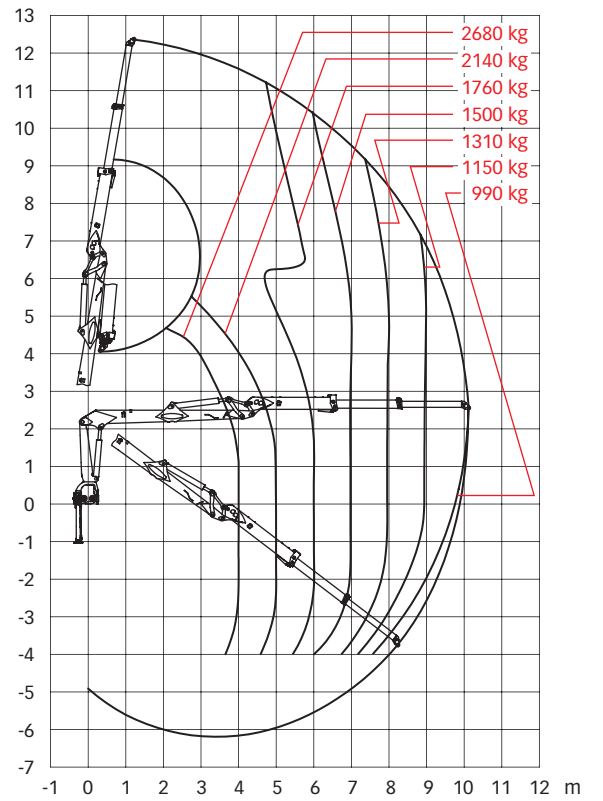

Disclaimer We reserve the right to make changes. Illustrations, drawings and data are not always in accordance with the latest version or standard model in production. The models in the pictures may present special equipment or colours.

Cargotec improves the efficiency of cargo flows on land and at sea – wherever cargo is on the move. Cargotec's daughter brands Hiab, Kalmar and MacGregor are recognised leaders in cargo and load handling solutions around the world.

www.cargotec.com

